

HOME WING



Newsletter of the Home Wing of Van's Air Force — Builders and Fliers of Van's RV Series Aircraft

First 2001 Issue



The Saturday morning breakfast flight arrives at Elma, WA. Photo by Randall Henderson

Editor's Hangar

Welcome to 2001, and to start off the new year properly we have a very full issue this time. This issue features tech articles from Mike Robbins and Larry Depute. And to give you something to dream about during the dreary winter days, flying stories from Kevin Lane and Mike McGee. Mike is now back from his winter trek to the Caribbean and has written part one of a story on this very interesting trip. Thanks very much to Mike, Larry, Kevin, and Mike for their contributions.

What will 2001 bring — perhaps some first flights for Home Wingers? Let's see, who should we be watching: will Mike Wilson fly his RV-4 now that it's painted? Isn't it about time for Bob Haan to fly his RV-

6A? Brent "the Toolmeister" Ohlgren has moved to the hangar and been holed up there quite a bit lately — ready to fly his RV-6? Maybe Rion Bourgeois' RV-4? Dale Wotring was working on the final wiring of his RV-6 and has moved it to his hangar at Pearson — ready to fly? And lastly, how about yours truly — will my RV-8 make it into the air this year? It should be fun to watch the Home Wing fleet grow.

As the host of the January meeting, I'm trying to get my paint job as far along as possible to show everyone. After what seemed like a lifetime, my cowling was shot a couple of weeks ago. No more sanding and filling!

Here's to a great 2001, and see you at the January meeting.

...Randy



Meeting coordinator:
 Randall Henderson
 503-297-5045
 randallh@home.com

MONTHLY MEETING:

(2nd Thursday every month, various locations, 7:00 pm)

Place: Randy Lervold's house
 5228 NW 14th Circle
 Camas, WA
Date: Thursday, January 11th, 2001
Time: 7:00 pm
Phone: 360-817-9091

The first Home Wing meeting of 2001 will be at Randy Lervold's house in Camas. He's been painting his RV-8 one piece at a time, so bring your paint questions for discussion.

DRIVING DIRECTIONS:

From Portland: Take Hwy 14 (on the Washington side of the Columbia river) east from either I-5 or I-205. Take 164th St exit, left at bottom of exit (north). Right on 34th at top of short hill (east). Go approximately 2 miles, turn right on Payne Rd. Wind up the hill until Sharp is on your left. Turn right on Deer Fern (entrance to Knight's Pointe subdivision). Take third right, NW 14th Circle, last house at bottom of hill.



Flying: Sorry.

Future meeting schedule:

- Feb: Help, we need a place!
- Mar: Bob Boring's RV-6A project (tentative)
- Apr: Jeff Jasinsky's project (tentative)
- May: Phil Spingola's RV-6 project (tentative)
- June: t.b.d.

Meeting places are always needed: if you'd be interested in hosting a meeting please contact Randall Henderson at 503-297-5045 or randallh@home.com

EAA CHAPTER 105 Pancake Breakfast:

First Saturday of every month at Twin Oaks Airpark, 8:00 am, \$5.00 (always lot's of RVs to look at too!)

This month: 1/6/2001

EAA CHAPTER 105 Monthly Meeting:

Third Thursday of every month at the EAA 105 hangar/clubhouse, Twin Oaks Airpark, 7:00 pm. See www.eaa105.org for details

This month: 1/18/2001

EAA CHAPTER 902 Monthly Meeting:

Second Wednesday of every month at the Mulino Airport in the OPA building. For info call Gary Sparks at 503-251-0843

This month: 1/10/2001



18th Annual Northwest Aviation Conference & Trade Show

February 24th & 25th, 2001
 Western Washington Fairgrounds
 Puyallup, Washington
www.washington-aviation.org

This is always a good mid-winter aviation "fix", with a variety of speakers and vendors. Phil Boyer and Rod Machado are among the featured speakers this year. If the weather is flyable, you can land at Pierce County/Thun field (1S0); there are free shuttles to and from the fairgrounds. If it's not flyable, well, its not too bad of a drive up there.

...Randall



December Meeting Recap

December '00 was our first meeting at the new Van's Aircraft facility. In addition to the usual new member introductions (quite a few!), Randy Simpson showed us the titanium tie-downs he makes and sells, appropriately called Ti-downs. He offered Home Wing members a special group price and proceeded to sell everything he brought. He has offered to extend this price to other Home Wingers since he sold out. Info can be obtained at his web site: www.airtimemfg.com.

Van then addressed the group introducing new staffers (quite a few), talking about the facility, and making a special appeal for Van's Air Force groups to stay involved with their local EAA Chapters, our local Chapter 105 in particular, to keep them vital.

Thanks to Van's Aircraft for hosting!

...ed

Another One Bites the Dust...

From AvWeb, 12/22/00:

THUNDER MUSTANG KIT MANUFACTURER CLOSES ITS DOORS:

Papa 51 Ltd., which formed in 1995 to produce a carbon-fiber 3/4-scale version of the P-51D Mustang, announced Tuesday that it has closed its doors. The company handed over its assets to the Thunder Builder Group, of Richmond, Texas, a group of 24 builders that formed last year in an effort to support Papa 51 so it could continue to build kit parts. The group is still building airplanes and hopes to find investors to keep the design in production.

The Canopy: Another Approach

By Mike Robbins

I decided early on that I was going to use screws to attach the canopy skirt/canopy/frame. I also thought it would look neat if I left the stainless steel screw heads unpainted. I also knew that I wanted to eliminate all gaps between the skirt and fuselage. Little did I know how much trouble that would be to achieve these goals.

I started the canopy project by taking off the protective plastic and laying a strip of blue masking tape down the approximate centerline of the canopy. I then marked the centerline on the tape and reapplied the plastic. I continued like everyone else by cutting off the bottom flange, then slowly taking off small slices of the canopy along the bottom, more from the top than from the sides and rear. My patient wife Jennifer was always at the ready to help me lift the canopy from the work bench to the frame and back each time I removed some material. This took about two weeks.

When the canopy was within about 1/8 of an inch above the canopy bow I made the big cut – separating the main canopy from the front windshield. I ended up removing about an inch of material above the reference line drawn on the windshield by Van's. It didn't seem right, but that's what it took to bring the canopy down and it worked out OK.



Next is where I started to deviate from the instructions. Since I was going to use screws instead of rivets along the bottom of the canopy, I decided to use "keeper screws" instead of keeper rivets to temporarily hold the canopy to the frame while fitting the skirt. And since I don't like drilling any more holes than necessary, I would put these keeper screws in some of the same holes that will be used for the permanent screws. Seemed like a good idea at the time, but I later found out this would not work.

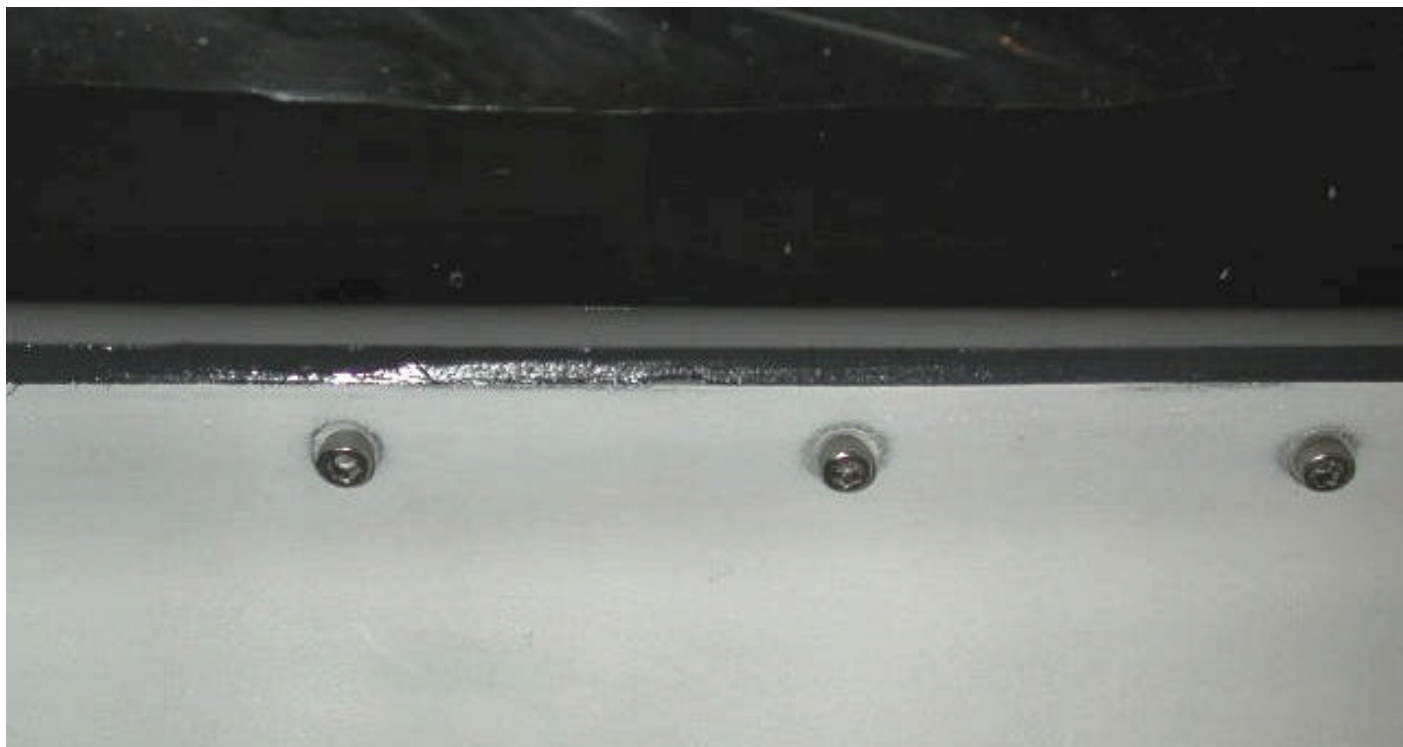

Temporary "keeper" screws and Proseal edge fillet.

I cut the canopy so that about an inch of material extended below the frame. I held the canopy to the frame using a bunch of clamps, then drilled through the canopy into the frame with a dull #40 drill, clecoing as I went. I put in more holes than the plans suggest in the area just ahead of where the frame changes tubing size in the back. This is where the canopy bulges out the most. I then marked where I wanted to put the keeper screws, and drilled them with a #36 drill. These holes would be tapped later for #6 screws. I used a 1/8 plastic drill to open up all the holes in the canopy, then followed with a #30 drill all the way through the frame. I removed all the clecoes and the canopy, deburred the holes in the canopy and frame, and tapped the holes in the frame for the keeper screws. I slightly countersunk those holes in the canopy that would have the keeper screws. As I was doing all this for the canopy frame I was also drilling the canopy bow. I left those holes at #40 as they would later be drilled to #36 and tapped.

I put the canopy back on the frame, first clamping it in place, then putting #30 clecoes in the frame, except where the keeper screws would go, and #40s in the bow.

Before going any further let me say that if I were to do it again I would put in the extra keeper holes now, because that is what I ended up doing later anyway when I tried attaching the skirt. I found out that you cannot attach the skirt to the canopy and frame without the canopy being secured in place onto the frame.

After putting in the keeper screws I was ready to

start on the skirt. With the keeper screws holding the canopy in place I removed all the #30 clecoes and tried fitting the skirt as it came, in one piece. Many have said I would end up cutting it in two, but I had to see how it fit as is. The older finish kits have one piece skirts. I understand the newer ones have the skirt already cut in two. Sure enough, it rode up way too high in the back and had big bulges along the sides. Sooo . . . I sliced the skirt right down the middle. It sure made it a lot easier to work with, and I didn't need a second person to help make the many trial fits over the next two months. Yes, two months working on the skirt alone.

I got the back close to where I wanted it, and started dealing with the gaps in the rear along the sides leading up to the very back portion. I would deal with the large gap at the rear after I reattached the two halves. The gap along the sides was as wide as 3/16 inch at one point on both sides. I tried using a heat gun to mold it into shape. This technique worked well on the empennage fairing, but the skirt has too much mass for it to work in this case.

What I ended up doing was building up the inside of the skirt with layers of fiberglass, tapering it from 1/32 of an inch at both ends and up to 3/16 in the middle. It was very time consuming and tedious, but it worked. When I was happy with the fit along the sides I decided it was time to reattach the two halves. But first I sanded and filled both the inside and outside with SuperFill. It was much easier doing it now when the halves were



ABOVE: The finished installation with the stainless steel #6 screws clearly visible.

BELOW: the fiberglass work on the inside rear of the skirt.



separated. I prepared the rear for a scarf joint, then clecoed the halves onto the canopy/frame. I put a bunch of layers of glass on the outside, let it cure, then carefully removed the reattached skirt (using two people) and put layers of glass on the inside. After curing and much sanding I installed the skirt to the canopy and found that a slight gap had reappeared along the sides. I dealt with that by mixing up some chopped mill fiber and epoxy until it was pretty stiff, then glopping it along the inside of the skirt where the gap was and reattaching the skirt after putting clear tape on the fuselage sides to protect it. Once cured, I now had a gap free skirt, except for the back. I built up the back around the slider rail with glass cloth and milled fiber/epoxy.

Now it was time to take everything off and install the rivnuts in the frame. I opened up all the holes to 3/16 for the #6 rivnuts and installed them (after painting the frame). I also opened up all the holes in the canopy to 3/16. I wasn't going to make the holes that big but I dis-

covered that I had to as the canopy moves around so much that the holes never seem to stay in the same place. I opened up the holes in the skirt with a #28 drill, except along the sides where the cross tube members are, as I used pop rivets here as per plans.

The next challenge was how to paint the skirt yet not the screw heads. What I did was initially use #6 stainless allen head cap screws (stainless because they were one half the price of the black steel ones, for some reason) to attach the skirt and canopy to the frame. Using cap screws left the outer perimeter of each countersunk hole exposed allowing paint into this area. At the skirt/canopy junction I used a 3M automotive sealer. The sealer was easy to apply and it turned out looking pretty good, but this sealer is not very robust and can be peeled off with a fingernail. If I were to do it again I would use something else like proseal in a syringe. So I completely fastened the skirt/canopy/frame using screws and pop rivets. Prior to this point I had filled and primed the skirt with Smooth Prime, and painted the inside with PPG Concept.

With the canopy masked off I filled the rivet holes with SuperFill (hope it doesn't fall out some day) then primed with many coats of PPG P36 primer. I went through the same prime/sand/prime/sand routine as the editor of this newsletter has previously described. After the final sanding I top coated with PPG Concept. I waited a week, then, one at a time, removed the cap screws and replaced each one with a stainless countersunk head screw.

Throughout this whole process I never had one crack. I was lucky. But then it hasn't flown yet either.

Would I go through all this again? Well . . . maybe. But it does look kinda cool.

...Mike



Getting to the Airport

By Larry DePute

When it came time to move my completed fuselage from my shop at home to the hangar at the airport for final assembly, I towed it using a simple tow hitch built from parts already in my shop.

I drilled a 3/8 inch hole just below the head of a 3/4 inch by 3 inch bolt. Then I cut some 3/8 inch I.D. tubing for spacers to center the tail wheel fork on the 3/4 inch bolt. I then double-nutted the 3/4 inch bolt in the trailer hitch hole in the bumper. Next I put a 3/8 inch bolt through the fork, spacers and the hole in the 3/4 in bolt, finger tightened a castellated nut and installed a cotter key. The 3/8 inch bolt provided vertical movement, and the tail wheel swivel provided horizontal movement. The brake shoes were removed to prevent friction.

Traveling back roads at 20 mph, the 2 mile trip to the airport went very well. I do not think that higher speeds on smooth roads would be a problem.

...Larry DePute
Flying RV-4 N144LD
Juneau, Alaska



TOP: Randy Griffin's fuselage prepares to go 35 mph in reverse. Note the bicycle strobe attached to the engine mount. **BOTTOM:** Randy's copy of Larry's design. To allow the fuselage to move longitudinally relative to the tow vehicle, Randy slotted the post where the cross bolt goes through... worked great.

Editors note: shamelessly copying a great idea, Randy Griffin and I stole Larry's idea and have successfully used it once already to transport Randy Griffin's fuselage up to my house for interior painting. See the two pictures above for details.

...RL

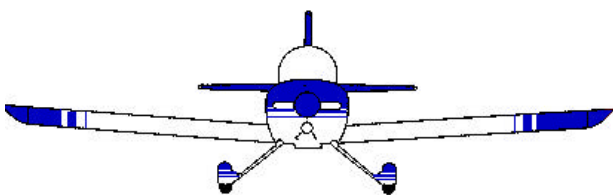



Fandango in an RV-4: Part 1

By Mike McGee

Aurora, Oregon, USA to Angel Falls, Venezuela (and back), in an RV-4, Part 1.

The short version:

This was a fantastic trip. It was long, it was a lot of work, there were a few things that could be done for the next one that will make it a little easier. There are some things that the plane could have that would make it an easier trip next time. Now that I've been there and done that, I want to do it again.

The longer version:

Just getting there

We planned to get out of Oregon VFR on Thanksgiving Day. We never even started the plane. In retrospect this wasn't a bad start to a trip like this. It cemented in our minds that we want to run a tight ship if not a tight schedule. We would go on to catch up with the rest of the group and enjoy what was a very unique vacation. Not necessarily a relaxing trip — it was quite a lot of work to go to 7 different countries in the span of 15 days. I was learning a lot along the way about international flying. This was one of the reasons I went on the trip and for that I got my money's worth.

The flight from Oregon to Florida was pretty routine by RV standards. This can be done easily in two days of flying even in the winter if you don't mind flying at night for a couple of hours. For a VFR plane though the plan from the beginning is that you have time to wait for the weather.

We got out of Oregon about noon the day after Thanksgiving. The fog lifted in the northern half of the valley and we headed south. We spent the first night in

Los Osos, CA after landing in San Louis Obispo. Diana's dad took the picture that appeared in the Last Home Wing NL with the SBP tower in the background just before we headed east.

Day two we got gas in Blythe, CA, then Demming, NM where we entertained a group of Army helicopter mechanics with showing off the plane and explaining where we were headed. We headed for our final stop of the day which was supposed to be Midland, TX, but called it quits at Carlsbad, NM when it started to get dark. After a good nights rest we got to the airport before sun up and cleaned the ice off the wings. We launched into the New Mexico sunrise and got to Corsicana, TX for the next fill up. Leg two took us to Fairhope, AL. The last leg of the day got us to Ocala, FL where we landed in the dark with an obvious alternator problem. We had lost two hours that day crossing time zones.

The next day in Ocala I pulled the cowling off and started trouble shooting. It should be noted that a strange RV on the ramp with the cowling off is an open invitation to other past, present, and future RVators, to stop by, introduce themselves, update you on how many RV's are on the field, see what's going on, and "oh, sure I know someone who can help with that alternator".

While we were moving cowling pieces to Carl's hanger and loading ourselves into Carl's car he showed off his very nice RV-4 sporting an army paint scheme. He hauled us way across town to an automotive electric shop that caters to the home-builders crowd where we found the alternator brushes had given their all for at least 100,000 miles. With fresh brushes and a good bench test we headed back and got the plane back in the air.

It could be speculated that we might have been at least a day behind without the repair time just due to the weather conditions. I know we could not have made it to Boca Raton that Sunday night and possibly not the next day. Many thanks to Carl Wood for his hospitality and helping out a couple of RVators a long way from home. Unfortunately 15 minutes out of Ocala the ammeter laid down again. Since this airplane, I like to call a J-3 cub-with-a-speed-kit, needed only electrical power to run the transponder and comm radio we pressed on to Boca Raton. Now I'm running through my head what I had done to the plane that in the last 20 hours might have killed an alternator. It had worked fine for a hundred hours prior. I had a new metal prop that was noticeably more "vibrant" than the wood props I had before. I also had cleaned up the baffling around the engine and blocked some air passages that "leaked" air to the underside. In retrospect the air leaks probably provided



Mike and Diana in Provo, Turks and Caicos Islands.

FSS) and without the security of the group we headed for Exuma International at Moss-town, Bahamas. After awhile, the angry butterflies backed off and we enjoyed the sight of the islands passing underneath. As it turned out we had better weather than the group did when they took off two days earlier. We did drop down low to go under some clouds a

cooling air to the alternator and my fix is what did it in.

We landed in Boca Raton and repeated the scenario from Ocala. A local retired airline pilot found working on his CJ (Chinese Yak) was good enough to haul us into Pompano where another shop put it on the bench and found the diodes and/or internal regulator had given up. We decided a complete overhaul was in order and he provided us with a fresh ready to go unit by the next day. During the installation I re-fixed the baffling to direct more air to the alternator and subsequently had no more problems for the rest of the trip. An hour before dark we went up for a shake down cruise that gave us a nice tour of the Florida coastline from Boca to Fort Pierce and back. Once again many thanks to a local experimental pilot Terry Lewis, for his assistance to the wayward travelers.

We met a number of fellow experimental and otherwise pilots while we were on the ground for two days in Boca Raton. It's actually very fun and interesting to go to a strange airport a long way from home and just wander the T-hangers looking for open doors with interesting planes and people inside...but that's another story.

0900, Wednesday November 29, two days behind the rest of the group, we blasted off from Florida and put the dry land at our backs. Water and butterflies... serious, angry, butterflies. With my first international flight plan filed (thanks to a very helpful Miami Int.

couple of times.

We landed at Exuma International for gas and a sandwich. The first customs clearance seemed easy and proved to be typical for most of the trip. Have a few General Declarations filled out when you get there and it saves some time. Of course in all the excitement, I was late in closing my flight plan with Miami. They were on the phone looking for me when I climbed up to the tower after landing. Full of fuel and food I filed the next leg to Providenciales, Turks and Caicos Islands. We climbed in and once again put the terra firma behind us. The leg to Provo wasn't as long and we lined up with the runway about 10 miles out.

When we landed and rolled to the ramp we could see a group of small planes that looked conspicuously out of place. On a ramp that wasn't used to having this many small planes, I spotted the C-195 of John and Sarah Hambleton and knew we had caught up with the group. Until this point, with weather delays, mechanical problems, and not even being sure if I was going to have the plane ready to leave Oregon in time, I would always say we were "trying" or "planning" to go to the Caribbean. I felt like I had crossed the finish line of my first marathon, we made it.

Next month, part 2, flying the islands.

*...Mike & Diana
RV-4 N996RV, Aurora, OR*

A Typical RV Saturday

By Kevin Lane

Recently my wife, Ellen, listened to a NPR program that was broadcast from Walla Walla, WA. She decided that we should visit the town some time and check out this long-held secret slice of American pie. The weather was gorgeous on Saturday as we left Troutdale full of fuel and with only one GPS waypoint: ALW, Walla Walla Regional, an hour twenty minute trip up the gorge.

Mt. Hood was sporting a lenticular cloud at it's summit as we flew up the gorge, and Adams and St. Helens were brilliant in a fresh coat of snow. As eastern Washington started rolling under us I commented on how the field's greens, tans, and browns were similar to the many subtle hues of the painted desert and just as pretty. Chinook approach dropped us off their radar coverage as we descended into ALW airspace. The tower asked what type of experimental we were and remarked that in the far, white hangar "Mike" was building an RV-8. We parked in the transient area and walked over to hangar, big enough to hold a dozen planes. There was Mike, busy sanding landing gear box parts. It turns out that Mike is a repeat offender, having once built a -4, the first to use a 180 HP engine. Mike has an "airport" car, an old diesel Rabbit with the headliner held up with some 2024 aluminum scraps, and offered it to us to ride into town to look about. He also insisted I bring my plane inside, an offer I never refuse (although hail seemed pretty remote!).

Ellen and I had lunch downtown (Walla Walla seems really into subs, we saw half a dozen sub shops) and strolled around Whitman College campus where a renaissance festival was taking place. The rock climbing competition up the side of the student union building was something new to me. We drove around some city neighborhoods and saw beautiful old homes near the college and restored brick buildings downtown. Housing costs seemed to be \$80K- \$100K less than Portland. But enough trivia, what about hangar space? How does \$85/mo for a heated shop at the airport sound? Three runways too, so you can always practice those cross-wind landings. Mike was born in Walla Walla and his job with the FAA, TRACON, took him to OK and even PDX. He is enjoying being retired and doesn't feel the push to complete the -8 like when he was building his -4.

On the trip home I tried rustling up Randall on 122.75 from Umatilla. Dave came back saying Randall wasn't around but he was over Mt. Jefferson making his

first Cascade crossing into eastern Oregon. Although he obviously recognized my voice I have no idea which Dave I was speaking to. Yes, I suffer from that engineer thang (the remembering names, not the spelling one).

Our outing was a lot of fun and a success. When Ellen usually rides with me we are headed for FL or NC. She enjoyed the short hop, the socializing, the adventure. There are still many adventures to be seized. So skip the paint job, forget the gear leg fairings, the wheel pants, the leather interior. Besides, there will always be long, rainy months in Oregon for building. The golden RV years are slipping by.

...Kevin

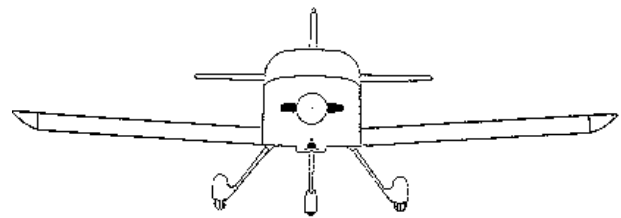

Tech Tips

by Brent Ohlgren

Whelen strobes (and others too)

While installing my strobes I stumbled on some info in the installation and specs. pamphlet. After the power supply has not functioned for a year it should be run through a start up sequence. I called Whelen and asked some questions. this turned out to be a good idea as they gave me a number of tips. The manual said to operate the unit at 25% reduced power for 10 min. to re initialize it If not you can blow the caps off the capacitors Here's their recommendation: discharge a battery down to 8 volts or less , connect it to the unit and run it for 15 min. Let it discharge for 5-10 min, run it again at 12volts for 15 min , let it discharge and your set to go. If you just plug it in and go there's a danger of overheating the the unit and ruining the capacitors

Hot Tip

When using washers as spacers in tight spots and you cannot get your fingers in to position it I used a 1/2" piece of .032 , 4" long ,with a "U" shape in the narrow end, sized for the washer to fit in. You then can position a washer to run the bolt thru

...Brent

Flying Activities

Coordinator: Randall Henderson

SUSPENDED FOR THE WINTER.

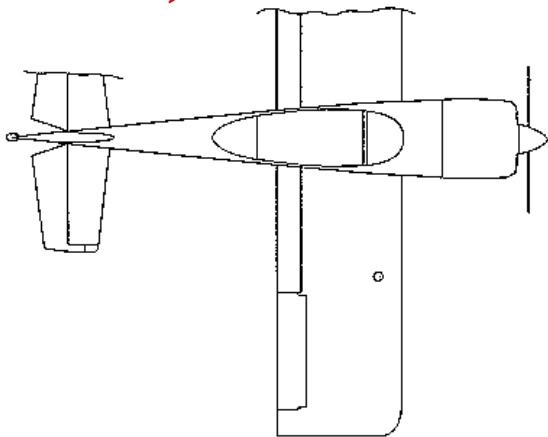

EAA Technical Counselors

Listed below are our Chapter 105 Tech Counselors:

Randall Henderson

503-297-5045, randallh@home.com

Dave Lewis, Sr.

503-690-8237

Don Wentz

503-543-2298, jwentz@columbia-center.org

EAA Technical counselors wanted! There are more and more new builders these days, and the three Technical Counselors we have could use some more help. If you've finished an RV, or hold an A&P rating, or are otherwise qualified under the EAA Technical Counselor guidelines, please consider signing up for the program, and adding your name to the list of EAA Technical Counselors available to the Home Wing and local EAA chapters.

1/1/2001

Builder's Bookstore
for the builder, technician, & pilot
<http://buildersbooks.com>



- Van's RV Specific**
18 Years of the RV-ator \$27.95
 (includes 21 year update pages in March)
- Orndorf Construction Videos full set
 Preview plans/manuals RV-3,4,6,8
 Aiming High 17.95
 The RV-Story - VHS 10.00

- Other RV Recommended Books**
- Aircraft Sheet Metal \$18.95
 - 43.13-B Accept. Methods 18.95
 - Bingelis - Sportplane Techniques 24.95
 - Bingelis - On Engines 24.95
 - Sky Ranch Engineering Manual 19.95

- AeroElectric Connection \$28.80
- Speed With Economy 24.95
- Nuts, Bolts, & Fasteners 21.95
- Lycoming Operator's Manuals 19.90
- Instruments & Avionics 23.95
- Taming the Tail Dragger 9.95
- Builder's Log Book 4.95
- Fiberglass 101 - VHS 25.95
- AC Painting 101 - VHS 25.95

See our on-line catalog for a complete listing with detailed descriptions. Always in stock. Same day shipping. Never a packing or handling fee.

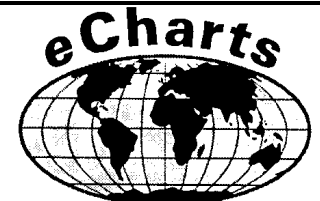
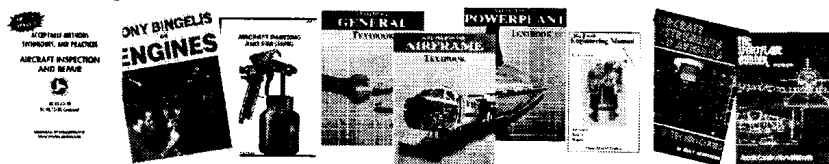

<http://eCharts.cc>

- Sectionals
- WAC charts
- AK Secs. & WACS
- TAC charts
- Facility directories
- Terminal plates
- Low Enroute charts
- 4 & 7 ring binders

- IFR/VFR Planning charts
- JNC 10' wall charts
- Flight Guides
- discounted Jeppesen services

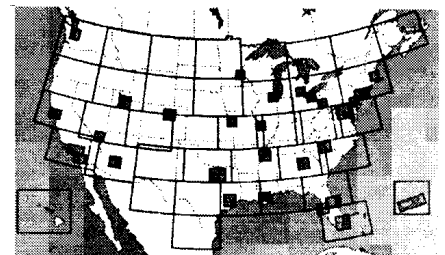

complete inventory
discount pricing, same day shipping
convenient subscription services

info@buildersbooks.com 970 887-2207 fax 970 887-2197 PO Box 270 Tabernash, CO 80478 info@eCharts.cc

CLASSIFIEDS...

Classifieds are free to Home Wing members. Ads will run for three months. Send to editor by e-mail or mail. Renewals ok, just let editor know. Date at end of the ad is last month ad scheduled to run.

FOR SALE

Engines for sales—Two IO-320-B1A fuel injected 160 hp engines from twin:

- 1,322 SMOH, \$9,900
- 455 SMOH, \$11,900

Both Dynafocal II. Contact Bill Drake 360-687-1698 or Al Strickfaden 360-687-3119, 3/01

Avery rivet/dimple arbor for sale - Good condition. \$90. Randall Henderson, 503-297-5045 randalh@home.com, 3/01

Paint For Sale — Changed my mind on paint schemes (twice) after buying paint. Have several unopened quantities of PPG Concept acrylic urethane available cheap:
1 gal. #13594 Spanish Blue (dark blue)
1 qt. #27381 Golden Mist Metallic
1 qt. #71844 Pop Red
Gallon: \$153, sell \$50. Quarts: \$57 new, sell \$25
Great for practice!
Randy Lervold, randy@rv-8.com, 360-817-9091

Lowrance Airmap 300 — For sale at \$575.00. Greg Halverson 503-591-0105, 12/00

For sale - D Square 3 1/8" Accelerometer -4.5 to +12G reconditioned in 1994 and used in a Cessna 182 for kicks -- it's like the proverbial old lady's car --- hardly used. \$175 contact John Warren at 360-263-7848, 3/01

Home for sale — LaCenter View Air strip. It would be nice to have another RV on the field. Its a 3 Bdrm ranch on 3.1 acres. The 1700' grass strip serves a total of six lots. Asking price is \$189,500. It's located 6 miles NE of the town of LaCenter and is noted on the Seattle sectional. John Warren 360-263-7848 for info (resident, not realtor), 3/01

Duckworks Landing Lights - Retro-fittable, light, easy installation. Kits start at \$69, discount for Home Wingers. Don Wentz, 503-696-7185

BACK ISSUES are available at \$2.00 each including postage for hardcopy. Limited availability, contact newsletter editor. Adobe Acrobat versions free to members.

WANTED

?

Use 'em!

Members are encouraged to take advantage of the classified section. Since it's free why not take a stab at unloading that unused airplane stuff. Besides, it's kind of interesting to look at all the odds 'n ends for sale.

Please note that the date at the end of each ad is the expiration date. They run for three months and then are dropped unless you want them renewed by notifying me.

...Randy

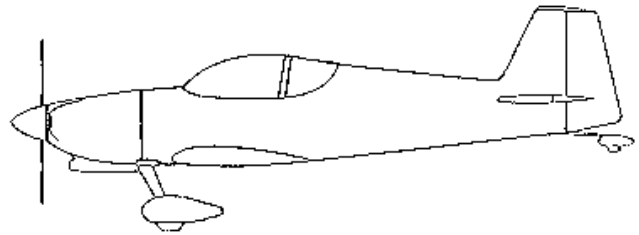

Newsletter Delivery

Our member database continues to hover around the 150 mark (presently 148). Newsletter delivery is split 68 mail, 80 e-mail. I'd like to encourage those still receiving b/w snail mail to switch to e-mail delivery. Some of the benefits include...

- **Faster delivery:** you receive the newsletter 2-3 days ahead of snail mail.
- **Full COLOR:** with the increasing use of photos this adds another dimension you don't want to miss.
- **Storage flexibility:** you can print it on your own printer, or leave it stored electronically, or both.

If you're interested but unsure let me send you a test copy. Just send me an e-mail (randy@rv-8.com) and I'll send you a test copy.

Lastly, I would encourage ALL members to make sure I have your e-mail address even if you don't get your newsletter that way. I occasionally send out e-mail to all on important notices.

Thanks!

...Randy

THE TOOL EXCHANGE

The Home Wing owns a selection of tools for use by its members. The Toolmeister is: **Brent Ohlgren, 503-288-8197, obrento@aracnet.com**. Please observe our Tool Policy:

Home Wing Tool Policy

- Everything goes through Brent — do not give the tool to another member.
- Brent will keep an accurate sign-out sheet for each item so he knows where it is at all times.
- Brent will inspect all tools upon their return. If there is any damage he will ask you to pay for the repair (with the threat of public humiliation if you fail to be a grown-up).

The ability to have use of these expensive tools is a real membership benefit, let's respect the group's assets.

Home Wing Tools

HVLP paint sprayer, turbine type. Includes gun and air turbine.
Hole template for instrument panel.
Wire crimping tool & die
Brake lining rivet set.
Tune-up & annual kit (compression checker, mag timing light, timing dial, mag adjustment tool, plug gapper, high voltage cable tester, and plug vibrator cleaner.
Aircraft scales — allows you to accurately weigh your beast and also determine CG.
Oil filter cutter—custom make by Stan V.

In addition to the Home Wing's tools, certain benevolent members have tools they may be willing to loan. Let the editor know if you have jigs, tools, or shop space to loan, exchange, or otherwise provide — at no cost — or if you are looking for something specific to borrow.

Tools For Loan

Item	Owner/lender	Phone / e-mail
Custom cutting wheel mandrel (for cutting your canopy)	Stan VanGrunsven	
Prop tach (calibrate your tach)	Mike McGee	503-534-1219, jmpcrftr@teleport.com
Engine stand	Don Wentz	503-696-7185
Surveyor's transit level (handy way to level wing and fuselage jigs)	Bill Kenny	503-590-8011
Back riveting contraption (large, counterweighted bucking bar and suspension system and offset back rivet sets)	Bob Neuner	503-771-6361
Lead crucible (for melting lead for elevator counterweights)	Doug Stenger	503-324-6993
Table saw taper jig (for tapering wing spar flange strips)	Carl Weston	503-649-8830
48" pan break located at hanger PLS D-10 at Troutdale if an RV builder needs some metal bent.	Kevin Lane	503-233-1818, n3773@mciworld.com
Aircraft tire bead breaker, for tire removal	Kevin Lane	503-233-1818, n3773@mciworld.com
Special letter drill used to ream rear spar bolts/straight reamer for rear spar/	Kevin Lane	503-233-1818, n3773@mciworld.com
Lasar T-300 magneto timing tool.	Randy Lervold	360-817-9091, randy@rv-8.com
Precision Steel Fuselage Jig for RV-6/6A	Bill Drake	360-687-1698, rv6134WD@uswest.net,

Home Wing info:

A non-profit volunteer organization dedicated to building and flying Van's RV Series Aircraft

Newsletter editor & publisher Randy Lervold 360-817-9091, randy@rv-8.com
 Membership (dues & database)..... Randy Lervold 360-817-9091, randy@rv-8.com
 Meeting coordinator Randall Henderson 503-297-5045, randallh@home.com
 Flying activities coordinator Randall Henderson 503-297-5045, randallh@home.com
 Annual fly-in leader Don Wentz 503-543-2298
 Home Wing web site www.edt.com/homewing
 Webmaster Randall Henderson randallh@home.com

Disclaimer: The Van's Air Force Home Wing newsletter is in no way a publication of Van's Aircraft or any other corporation. All products reviewed or mentioned are not necessarily recommended for use by the Home Wing, but are included for informational purposes only. All builders tips represent only the means by which the builder whose name is associated with the tip chose to build his/her aircraft. Builder's tips are not meant to replace the plans and instructions from Van's Aircraft. All builder's tips are presented only as a source of information and a forum for exchange and the sharing of ideas and construction methods. NO responsibility or liability is assumed, expressed, or implied as to the suitability, accuracy, safety or approval thereof. Any party using the suggestions, ideas, or examples does so at their own risk and discretion and without recourse against anyone. The editor of the Home Wing newsletter and the builder's tips submitters are not responsible for any product or builder's tips misuse, incorrect construction, or design failure, nor any other peril. Any material printed within may be reprinted without permission, but please give credit to the original source and author. If the original source is not the Home Wing newsletter, it is not necessary to credit the Home Wing newsletter, only the original source and author. The Home Wing newsletter is published more or less monthly. Subscriptions are \$10/year. Complimentary issue for new builders upon request. Mail or e-mail all subscriptions, ideas, tips, tricks, and articles to the newsletter editor.

Home Wing Membership Sign-up/Renewal

To join or renew, fill out this form and mail to **Randy Lervold, 5228 NW 14th Circle, Camas, WA 98607**, along with \$10 for renewals or new subscriptions. **Please make checks payable to either Randy Lervold or Home Wing.** If you are renewing you only need to give your name, payment method, and any other information that has changed. Please don't forget your e-mail address and newsletter distribution method.

Use this form for address changes too!

Name: _____ Home phone: _____
 Address: _____ Work phone: _____
 City, State, Zip: _____ E-Mail: _____

Project: RV-3 <input type="checkbox"/> RV-4 <input type="checkbox"/> RV-6 <input type="checkbox"/> RV-6A <input type="checkbox"/> RV-8 <input type="checkbox"/> RV-8A <input type="checkbox"/> RV-9A <input type="checkbox"/>	Status: Not started <input type="checkbox"/> Empennage <input type="checkbox"/> Wings <input type="checkbox"/> Fuselage <input type="checkbox"/> Finish kit <input type="checkbox"/> Flying <input type="checkbox"/>	Newsletter Distribution: Mail <input type="checkbox"/> E-mail (pdf) <input type="checkbox"/>	Payment: Check <input type="checkbox"/> Cash <input type="checkbox"/> Info change only <input type="checkbox"/>
---	---	---	---